

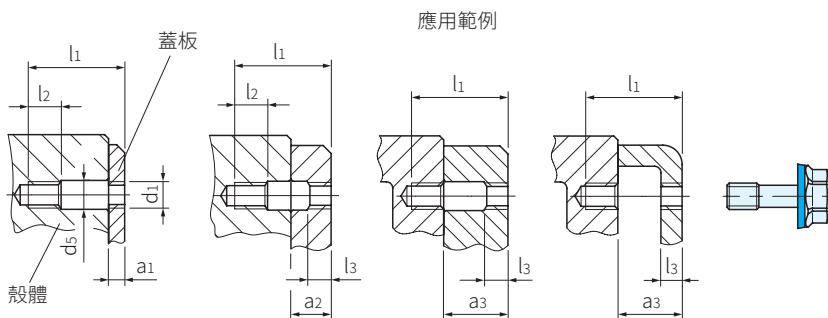

本體			型式	5
材質	處理	3		
SUS316L	亞光 (Ra<0.8μm)	MT	不含鎖定 墊圈	1
	拋光 (Ra<0.8μm)	PL		

密封環				
材質	4	顏色	耐溫	硬度
H-NBR	H	藍	-25°C~150°C	蕭氏A85±5
EPDM	E		-40°C~120°C	

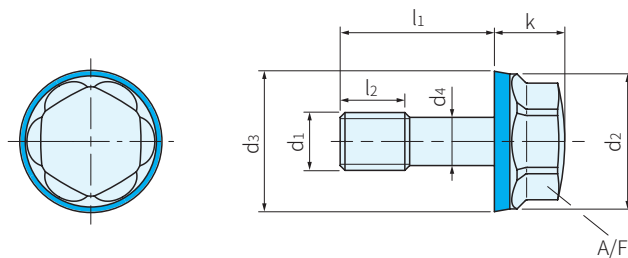

TYPE	1		2			d ₂	d ₃	d ₄	d ₅	k	l ₂	l ₃	A/F	庫存
	d ₁	l ₁	a ₁	a ₂	a ₃									
GN1582	M5	20	2.5-6	6-10.5	10.5-14	11	11.8	4	5.5	7	6	2.5	8	△
	M5	25	6-11	11-14	14-19	11	11.8	4	5.5	7	6	2.5	8	△
	M6	25	3-7	7-13	13-17	13	13.8	4.8	6.5	7.5	8	3	10	△
	M6	30	7-12	12-17	17-22	13	13.8	4.8	6.5	7.5	8	3	10	△
	M8	30	4-8	8-16	16-20	16	16.8	6.5	8.5	8.5	10	4	13	△
	M8	40	8-18	18-25	25-30	16	16.8	6.5	8.5	8.5	10	4	13	△
	M10	40	5-14	14-19	19-28	19	19.8	8.2	10.5	9.5	12	5	16	△
	M10	50	14-24	24-28	28-38	19	19.8	8.2	10.5	9.5	12	5	16	△

PS. 備註

- GN1582不銹鋼薄型頭部的螺絲通過EHEDG認證，因此非常適合在衛生區域使用
- 凹陷的頸部，可防止脫落

1 2 3 4 5
 訂貨： TYPE - d₁ - l₁ - 處理 - 密封圈材質 - 型式 交期： 10 天
 GN1582 - M10 - 50 - PL - H - 1